

**King Headz
KP-216
Losi 8ight EZ Change
Motor Mount**

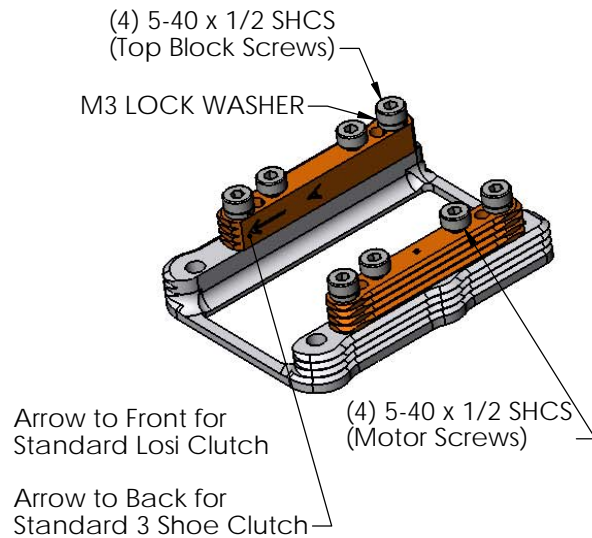

FINAL ASSEMBLY

- 1) ASSEMBLE THE MOTOR ONTO THE TOP BLOCKS
DO NOT TIGHTEN SCREWS AT THIS POINT
(4) 5-40 X 1/2" SCREWS.
- 2) ASSEMBLE THE BASE ONTO THE CHASSIS
DO NOT TIGHTEN - LEAVE LOOSE SO IT IS ABLE TO FLOAT.
(4) 8-32 MOUNT SCREWS SUPPLIED WITH YOUR KIT
- 3) ASSEMBLE THE TOP BLOCKS AND MOTOR ASSEMBLY
ONTO THE BASE INSTALL AND TIGHTEN
THE (4) 5-40 X 1/2" SCREWS AND LOCK WASHERS.
- 4) TIGHTEN THE (4) 5-40 X 1/2" HOLDING THE
MOTOR TO THE TOP BLOCKS
- 5) ADJUST MOUNT TO GET DESIRED GEAR MESH.
- 6) TIGHTEN (4) 8-32 MOUNTING SCREWS.

BY REMOVING THE (4) 5-40 X 1/2" SCREWS AND
LOCK WASHERS IT WILL BE "EZ" TO REMOVE THE
MOTOR AND REINSTALL IT WITHOUT A NEED
TO RESET THE GEAR MESH.

By flipping the top blocks
this will move the motor
forward 2mm. This will allow
you to run a standard 3 shoe
clutch without using an excessive
amount of shims.

**King Headz
KP-216
Losi 8ight EZ Change
Motor Mount**

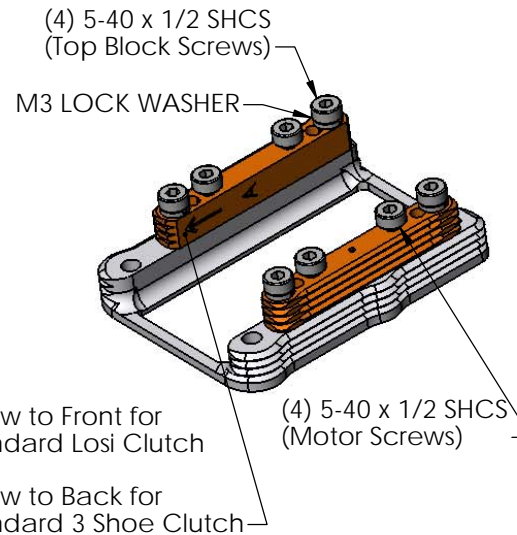

FINAL ASSEMBLY

- 1) ASSEMBLE THE MOTOR ONTO THE TOP BLOCKS
DO NOT TIGHTEN SCREWS AT THIS POINT
(4) 5-40 X 1/2" SCREWS.
- 2) ASSEMBLE THE BASE ONTO THE CHASSIS
DO NOT TIGHTEN - LEAVE LOOSE SO IT IS ABLE TO FLOAT.
(4) 8-32 MOUNT SCREWS SUPPLIED WITH YOUR KIT
- 3) ASSEMBLE THE TOP BLOCKS AND MOTOR ASSEMBLY
ONTO THE BASE INSTALL AND TIGHTEN
THE (4) 5-40 X 1/2" SCREWS AND LOCK WASHERS.
- 4) TIGHTEN THE (4) 5-40 X 1/2" HOLDING THE
MOTOR TO THE TOP BLOCKS
- 5) ADJUST MOUNT TO GET DESIRED GEAR MESH.
- 6) TIGHTEN (4) 8-32 MOUNTING SCREWS.

BY REMOVING THE (4) 5-40 X 1/2" SCREWS AND
LOCK WASHERS IT WILL BE "EZ" TO REMOVE THE
MOTOR AND REINSTALL IT WITHOUT A NEED
TO RESET THE GEAR MESH.

By flipping the top blocks
this will move the motor
forward 2mm. This will allow
you to run a standard 3 shoe
clutch without using an excessive
amount of shims.

**King Headz
KP-216
Losi 8ight EZ Change
Motor Mount**

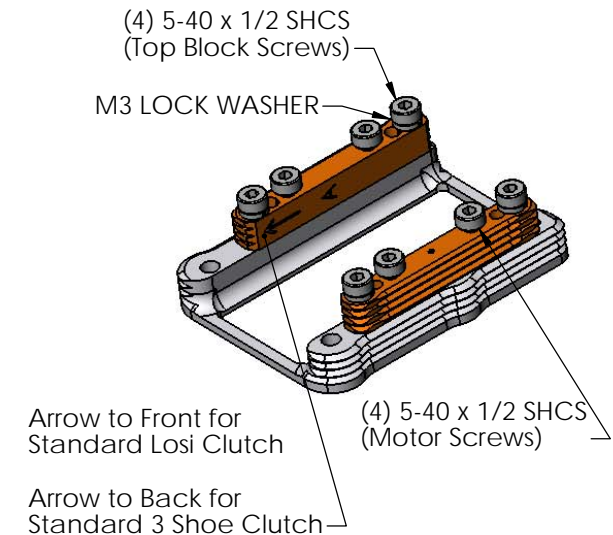

FINAL ASSEMBLY

- 1) ASSEMBLE THE MOTOR ONTO THE TOP BLOCKS
DO NOT TIGHTEN SCREWS AT THIS POINT
(4) 5-40 X 1/2" SCREWS.
- 2) ASSEMBLE THE BASE ONTO THE CHASSIS
DO NOT TIGHTEN - LEAVE LOOSE SO IT IS ABLE TO FLOAT.
(4) 8-32 MOUNT SCREWS SUPPLIED WITH YOUR KIT
- 3) ASSEMBLE THE TOP BLOCKS AND MOTOR ASSEMBLY
ONTO THE BASE INSTALL AND TIGHTEN
THE (4) 5-40 X 1/2" SCREWS AND LOCK WASHERS.
- 4) TIGHTEN THE (4) 5-40 X 1/2" HOLDING THE
MOTOR TO THE TOP BLOCKS
- 5) ADJUST MOUNT TO GET DESIRED GEAR MESH.
- 6) TIGHTEN (4) 8-32 MOUNTING SCREWS.

BY REMOVING THE (4) 5-40 X 1/2" SCREWS AND
LOCK WASHERS IT WILL BE "EZ" TO REMOVE THE
MOTOR AND REINSTALL IT WITHOUT A NEED
TO RESET THE GEAR MESH.

By flipping the top blocks
this will move the motor
forward 2mm. This will allow
you to run a standard 3 shoe
clutch without using an excessive
amount of shims.