

**King Headz
MBX6-015
Mugen MBX-6
EZ Change
Motor Mount - Extended**

(4) M3 X 14MM SHCS
(Top Block Screws)

M3 LOCK WASHER

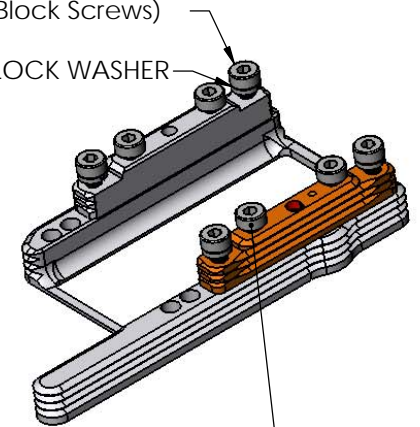

(4) M3 X 10MM SHCS
(Motor Screws)

- 1) ASSEMBLE THE MOTOR ONTO THE TOP BLOCKS
DO NOT TIGHTEN SCREWS AT THIS POINT
(4) M3 X 10MM SCREWS.
- 2) ASSEMBLE THE BASE ONTO THE CHASSIS
DO NOT TIGHTEN - LEAVE LOOSE SO IT IS ABLE TO FLOAT.
(4) MOTOR MOUNT SCREWS SUPPLIED WITH YOUR KIT
- 3) ASSEMBLE THE TOP BLOCKS AND MOTOR ASSEMBLY
ONTO THE BASE INSTALL AND TIGHTEN
THE (4) M3 X 14MM SCREWS AND LOCK WASHERS.
- 4) TIGHTEN THE (4) M3 X 10MM HOLDING THE
MOTOR TO THE TOP BLOCKS
- 5) ADJUST MOUNT TO GET DESIRED GEAR MESH.
- 6) TIGHTEN (4) MOTOR MOUNTING TO CHASSIS SCREWS.

BY REMOVING THE (4) M3 X 14MM SCREWS AND
LOCK WASHERS IT WILL BE "EZ" TO REMOVE THE
MOTOR AND REINSTALL IT WITHOUT A NEED
TO RESET THE GEAR MESH.